

Axis-QRA

Axial wall fans

Use

- Supply and extract ventilation systems installed in various premises.
- Mounting in ventilation systems with low static pressure requiring high air capacity.
- Direct air extract.



Air flow:
up to 1700 m³/h
472 l/s



Power:
from 26 W



Noise level:
from 31 dBA



Design

- Compact steel casing covered with special polymer coating.
- Aluminium impeller.
- The casing is equipped with a round mounting plate and flange for easy surface wall mounting.
- The fan is equipped with a power cord and external terminal box for connection to power mains.

Motor

- Single-phase asynchronous motor with an internal rotor and an axial impeller.
- Motor with slide bearings.
- Integrated overheating protection with automatic restart.

Speed control

- Smooth speed control with an external thyristor controller or step speed control with an external auto transformer (both available upon separate order).

Mounting

- Wall surface mounting with a round connecting frame.
- Horizontal installation with respect to air flow direction in the system.
- Power supply through an external terminal box with electric lead-in.

Designation key

Series	Dimension type
Axis-QRA	150: branch pipe ø 162 mm
	200: branch pipe ø 208 mm
	250: branch pipe ø 262 mm
	315: branch pipe ø 312/315 mm

Overall dimensions [mm]

Type	ØD	ØD1	ØD2	Ød	L	Weight [kg]
Axis-QRA 150	162	190	220	7	120	1.91
Axis-QRA 200	208	270	300	7	120	2.50
Axis-QRA 250	262	330	360	7	140	4.10
Axis-QRA 315	312	390	420	9	170	5.24

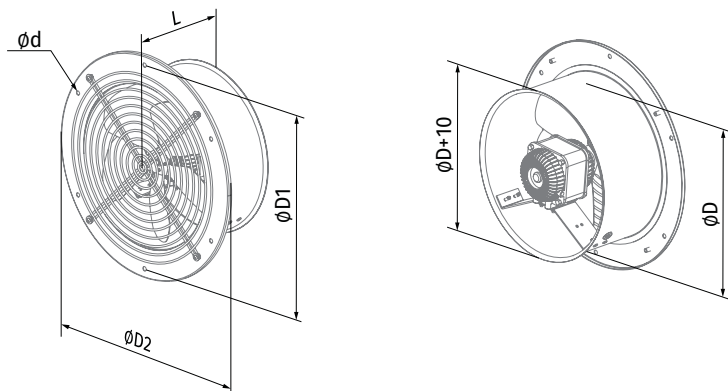

Accessories

Speed controller



CDT E1.8

Technical data

Parameters	Axis-QRA 150		Axis-QRA 200		Axis-QRA 250		Axis-QRA 315	
Voltage [V]	1 ~ 230		1 ~ 230		1 ~ 230		1 ~ 230	
Frequency [Hz]	50	60	50	60	50	60	50	60
Power [W]	36	26	43	33	68	76	110	104
Current [A]	0.26	0.26	0.28	0.21	0.48	0.51	0.75	0.7
Maximum air flow [m³/h (l/s)]	200 (56)	205 (57)	405 (113)	470 (131)	1070 (297)	1050 (292)	1700 (472)	1650 (458)
RPM [min⁻¹]	1300	1590	1300	1615	1300	1450	1300	1365
Sound pressure at 3 m [dBA]	33	33	32	32	37	37	42	43
Max. transported air temperature [°C]	40	40	40	40	40	40	40	40
SEC class	-		-		-		-	
Ingress protection rating	IP24		IP24		IP24		IP24	
Motor IP rating	IP44		IP44		IP44		IP44	
ErP	-		-		-		-	

AXIS-QRA 150

Sound power level, A-weighted	Octave frequency bands [Hz]								LpA, 3 m dBA	LpA, 1 m dBA	
	Gen.	63	125	250	500	1000	2000	4000			8000
LWA to environment [dBA]	54	22	35	39	45	49	49	45	39	33	43

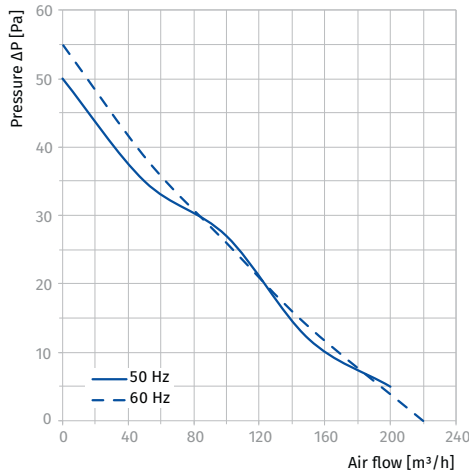

AXIS-QRA 200

Sound power level, A-weighted	Octave frequency bands [Hz]								LpA, 3 m dBA	LpA, 1 m dBA	
	Gen.	63	125	250	500	1000	2000	4000			8000
LWA to environment [dBA]	53	22	34	38	44	48	48	44	38	32	42

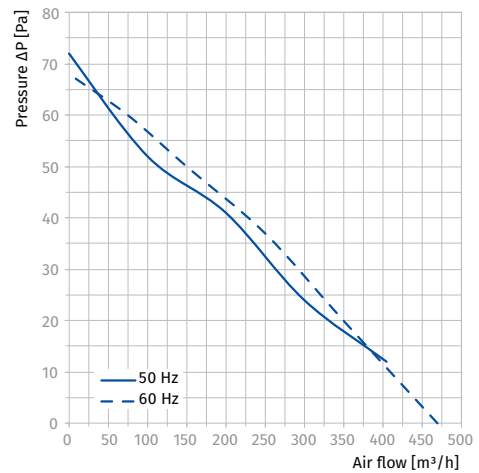

AXIS-QRA 250

Sound power level, A-weighted	Octave frequency bands [Hz]								LpA, 3 m dBA	LpA, 1 m dBA	
	Gen.	63	125	250	500	1000	2000	4000			8000
LWA to environment [dBA]	58	24	38	42	48	53	53	48	42	37	47

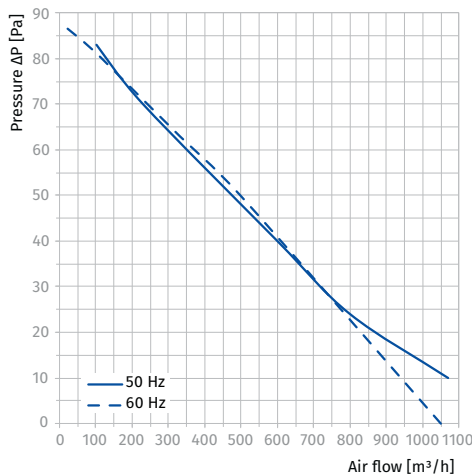

AXIS-QRA 315

Sound power level, A-weighted	Octave frequency bands [Hz]								LpA, 3 m dBA	LpA, 1 m dBA	
	Gen.	63	125	250	500	1000	2000	4000			8000
LWA to environment [dBA]	62	39	49	44	50	56	49	42	60	42	52

